

A16 Planfräser *Face mills, Fraises à surfacer, Frese a spianare*

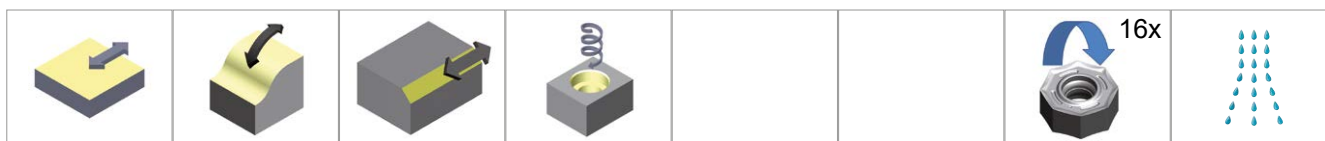

Aufsteckfräser *Shell type mills, Fraises à alésage, Frese per attacco a manicotto*

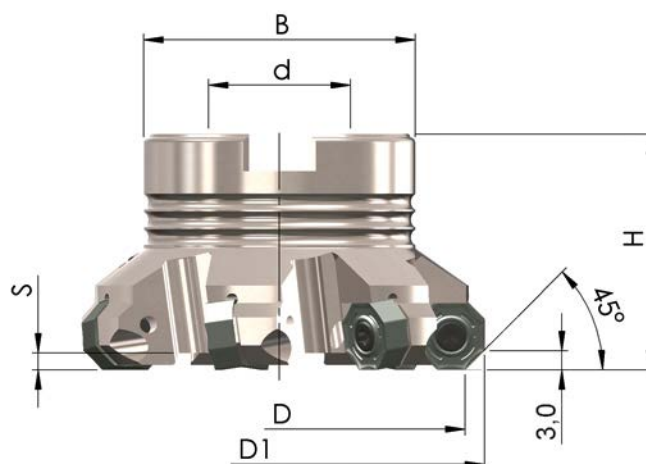

| Bestell-Nr. <i>Order-No., Référence, Codice</i> | D | D ₁ | H | d | B | S | Z | MS |
|--|-----|----------------|----|----|----|-----|----|---------------|
| 45PP-040-538-4 | 40 | 47,4 | 40 | 22 | 38 | 2,9 | 4 | MS-10x25-912 |
| 45PP-050-538-5 | 50 | 57,4 | 40 | 22 | 46 | 2,9 | 5 | MS-10x25-912 |
| 45PP-063-538-5 | 63 | 70,4 | 40 | 22 | 46 | 2,9 | 5 | MS-10x25-912 |
| 45PP-080-538-6 | 80 | 87,4 | 50 | 27 | 58 | 2,9 | 6 | MS-12x30-912 |
| 45PP-100-538-9 | 100 | 107,4 | 50 | 32 | 78 | 2,9 | 9 | MS-16x30-912 |
| 45PP-125-538-10 | 125 | 132,4 | 63 | 40 | 90 | 2,9 | 10 | MS-20x55-7991 |
| Enge Teilung <i>close pitch, à pas réduit, a passo stretto:</i> | | | | | | | | |
| 45PP-040-538-5 | 40 | 47,4 | 40 | 22 | 38 | 2,9 | 5 | MS-10x25-912 |
| 45PP-050-538-6 | 50 | 57,4 | 40 | 22 | 46 | 2,9 | 6 | MS-10x25-912 |
| 45PP-063-538-7 | 63 | 70,4 | 40 | 22 | 46 | 2,9 | 7 | MS-10x25-912 |
| 45PP-080-538-9 | 80 | 87,4 | 50 | 27 | 58 | 2,9 | 9 | MS-12x30-912 |
| 45PP-100-538-11 | 100 | 107,4 | 50 | 32 | 78 | 2,9 | 11 | MS-16x30-912 |
| 45PP-125-538-13 | 125 | 132,4 | 63 | 40 | 90 | 2,9 | 13 | MS-20x55-7991 |

MS= Mittenschraube *Central screw, Vis centrale, Vite centrale di fissaggio*

A16 Planfräser *Face mills, Fraises à surfer, Frese a spianare*

Schafffräser DIN 1835-B *Shank type mills, Fraises à queue Weldon, Frese a gambo Weldon*

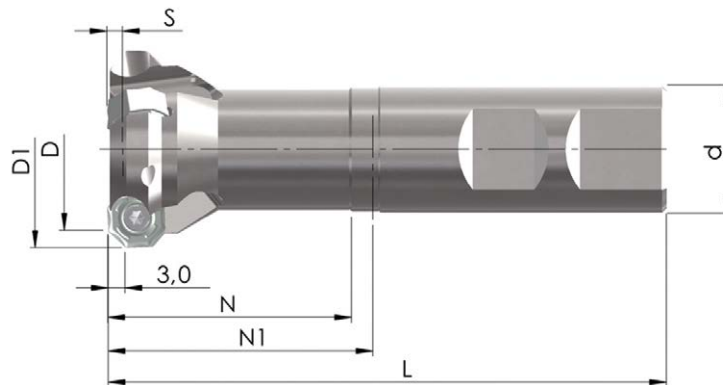

| Bestell-Nr. Order-No., Référence, Codice | D | D ₁ | N | N ₁ | L | d | S | Z |
|--|----|----------------|----|----------------|-----|----|-----|---|
| 45PP-20-20-538-2 | 20 | 27,4 | 32 | 48 | 100 | 20 | 2,9 | 2 |
| 45PP-25-25-538-2 | 25 | 32,4 | 32 | 42 | 100 | 25 | 2,9 | 2 |
| 45PP-32-25-538-3 | 32 | 39,4 | 48 | 52 | 110 | 25 | 2,9 | 3 |
| 45PP-32-32-538-3 | 32 | 39,4 | 48 | 48 | 110 | 32 | 2,9 | 3 |
| Enge Teilung <i>close pitch, à pas réduit, a passo stretto:</i> | | | | | | | | |
| 45PP-25-25-538-3 | 25 | 32,4 | 32 | 42 | 100 | 25 | 2,9 | 3 |

A16 Fräswendeplatten und Schnittdaten

Milling inserts and parameters, Plaquettes de fraisage et paramètres, Inserti e parametri di taglio

| | | | HC45 (code 41) | HT45 (code 31) | HT32 (code 33) | HC30 (code 52) | XC35 (code 46) | XC34 (code 64) | HT20 (code 32) |
|--|--|-----------|------------------------------|------------------------------|------------------------------|------------------------------|------------------------------|------------------------------|------------------------------|
| | JMA16-538- IK 11,4x5,2 H M | Order-No. | | A16DN -31-A | A16CL -33-A | | | | A16BD -32-A |
| | f_z [mm] | | | 0,15 (0,10-0,30) | 0,15 (0,10-0,30) | | | | 0,20 (0,15-0,50) |
| | JMA16-738- IK 11,4x5,2 M S | Order-No. | A16DR -41-B | | | A16CP -52-B | A16ES -46-B | A16FC -64-B | |
| | f_z [mm] | | 0,15 (0,10-0,30) | | | 0,15 (0,10-0,30) | 0,15 (0,10-0,30) | 0,15 (0,10-0,30) | |
| | JMA16-838- IK 11,4x5,2 M S | Order-No. | | A16HW -31-B | A16GU -33-B | | | | A16FT -32-B |
| | f_z [mm] | | | 0,15 (0,10-0,30) | 0,15 (0,10-0,30) | | | | 0,20 (0,15-0,50) |
| | | | 20 | 20 | 20 | 20 | 20 | 20 | 20 |

| V_c [m/min] | Stahl Steel Acier Acciaio | Rostfrei Stainless Acier inoxydable Inossidabile | Guss Cast iron Fonte Ghisa | NE-Metalle Non-ferrous metals Non ferreux Metalli non ferrosi | Hochwarmfest Highly heat-resistant Superalliages Resistente al calore | Gehärtet Tempered Aciers traités Temprato |
|------------------|------------------------------------|---|-------------------------------------|--|--|--|
| HC45 | 250 (200 - 350) | 240 (140 - 300) | 240 (130 - 280) | | | |
| HT45 | 250 (200 - 350) | 240 (140 - 300) | 240 (130 - 280) | | | |
| HT32 | 250 (200 - 350) | 240 (140 - 300) | | | 60 (40 - 200) | |
| HC30 | 160 (120 - 220) | 200 (100 - 300) | | | 60 (40 - 200) | |
| XC35 | 120 (60 - 120) | 100 (60 - 180) | | | 80 (40 - 200) | |
| XC34 | | 100 (60 - 180) | | | 80 (40 - 200) | |
| HT20 | | | 260 (180 - 350) | | | 80 (40 - 120) |

Ersatzteile Spare parts, Pièces de rechange, Parti di ricambio

| | | | | | |
|--|-------------------------------------|--|-------------|--|--|
| | SS 3,5-2 (M = 2,3-2,5 Nm) | | T 15 | | Fett Grease, Graisse, Grasso |
|--|-------------------------------------|--|-------------|--|--|