

## B29 Eckfräser 90° *Step mills, Fraises à 90°, Frese per spallamenti retti*

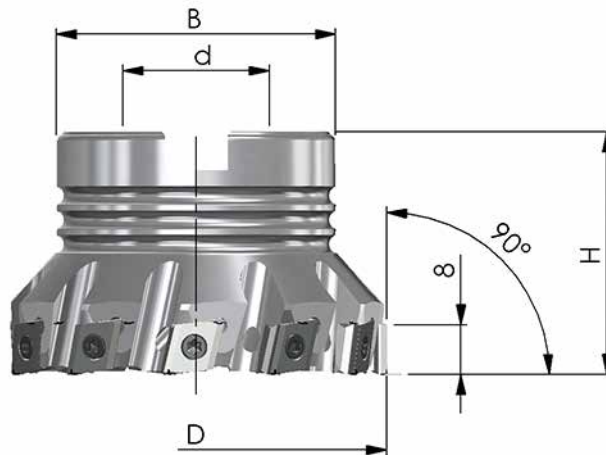

## Aufsteckfräser *Shell type mills, Fraises à alésage, Frese per attacco a manicotto*



Bestell-Nr. <i>Order-No., Référence, Codice</i>	D	H	d	B	Z	MS
90PP-032-B29-4	32	40	16	30	4	MS-8x25-912
90PP-040-B29-5	40	40	16	38	5	MS-8x25-912
90PP-050-B29-6	50	40	22	46	6	MS-10x25-912
90PP-063-B29-8	63	40	22	46	8	MS-10x25-912
90PP-080-B29-10	80	50	27	58	10	MS-12x35-912
<b>Enge Teilung</b> <i>close pitch, à pas réduit, a passo stretto:</i>						
90PP-032-B29-5	32	40	16	30	5	MS-8x25-912
90PP-040-B29-6	40	40	16	38	6	MS-8x25-912
90PP-050-B29-8	50	40	22	46	8	MS-10x25-912
90PP-063-B29-11	63	40	22	46	11	MS-10x25-912
90PP-080-B29-13	80	50	27	58	13	MS-12x35-912

MS= Mittenschraube *Central screw, Vis centrale, Vite centrale di fissaggio*

## B29 Eckfräser 90° *Step mills, Fraises à 90°, Frese per spallamenti retti*



### Schaftfräser DIN 1835-B *Shank type mills, Fraises à queue Weldon, Frese a gambo Weldon*

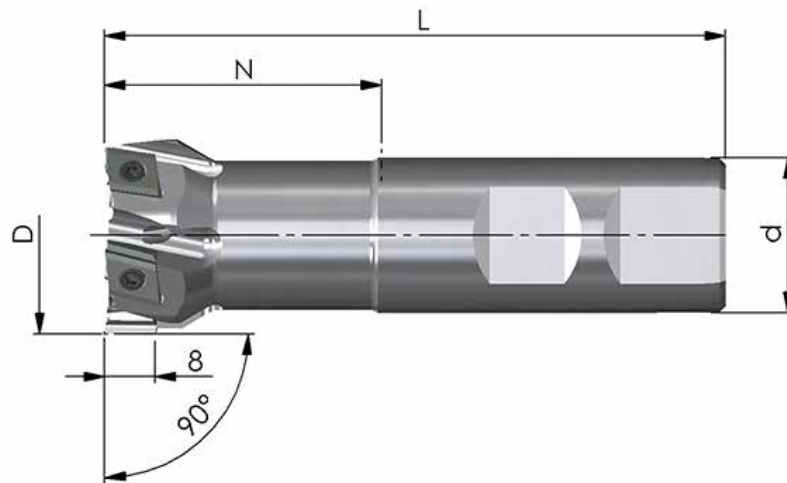

Bestell-Nr. <i>Order-No., Référence, Codice</i>	D	N	L	d	Z
90PP-25-44-25-B29-3	25	44	100	25	3
90PP-32-44-25-B29-4	32	44	100	25	4
90PP-32-44-32-B29-4	32	44	104	32	4
90PP-40-44-32-B29-5	40	44	104	32	5

## B29 Vielzahnfräser

Multi-Tooth milling cutters, Fraises multi-dents (hérisson),  
Frese a riccio





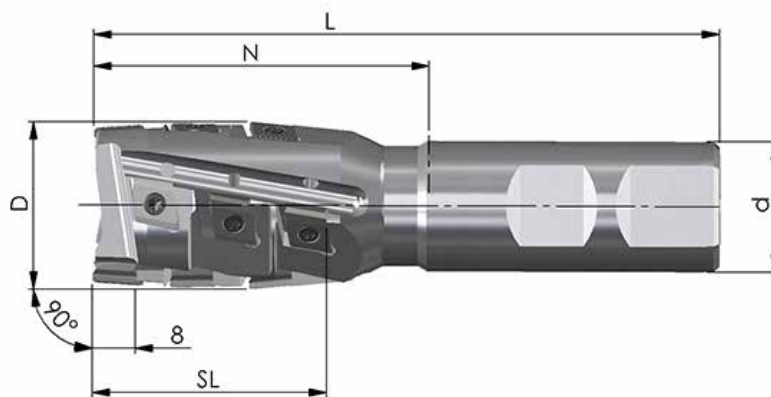



Schaftfräser DIN 1835-B Shank type mills, Fraises à queue Weldon, Frese a gambo Weldon



Bestell-Nr. <i>Order-No., Référence, Codice</i>	D	SL	N	L	d	Z <sub>eff.</sub>	ZZ
VZF-25-44-25-B29-2	25	45	63	120	25	2	12
VZF-28-44-25-B29-2	28	45	63	120	25	2	12
VZF-32-44-25-B29-2	32	45	63	120	25	2	12
VZF-32-44-32-B29-2	32	45	59	120	32	2	12
VZF-40-44-32-B29-3	40	45	59	120	32	3	18

## B29 Fräswendepplatten und Schnittdaten

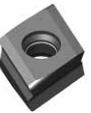
Milling inserts and parameters, Plaquettes de fraisage et paramètres, Inserti e parametri di taglio

			HC45 (code 41)	HC30 (code 52)	HC35 (code 50)	XC35 (code 46)	HC20 (code 53)	K15M (code 8)	
	<b>JMB29-T08PR06-</b> IK 8,0x4,0 R0,6 + Fase*	Order- No.	<b>B29A-TZ41</b>	<b>B29A-YL52</b>			<b>B29A-WA53</b>		
		f <sub>z</sub> [mm]	0,15 (0,05-0,25)	0,15 (0,05-0,25)			0,15 (0,05-0,25)		
	<b>JMB29-T08GR06-</b> IK 8,0x4,0 R0,6	Order- No.	<b>B29B-AX41</b>		<b>B29B-SM50</b>	<b>B29B-KZ46</b>	<b>B29B-YU53</b>		
		f <sub>z</sub> [mm]	0,15 (0,05-0,25)		0,15 (0,05-0,25)	0,15 (0,05-0,25)	0,15 (0,05-0,25)		
	<b>JMB29-T08GR02-</b> IK 8,0x4,0 R0,2	Order- No.						<b>B29B-RW08</b>	
		f <sub>z</sub> [mm]						0,20 (0,15-0,25)	
			20	20	20	20	20	20	

\* Fase, chamfer, avec chanfrein, smusso

V <sub>c</sub> [m/min]	Stahl Steel Acier Acciaio	Rostfrei Stainless Acier inoxydable Inossidabile	Guss Cast iron Fonte Ghisa	NE-Metalle Non-ferrous metals Non ferreux Metalli non ferrosi	Hochwarmfest Highly heat-resistant Superalliages Resistente al calore	Gehärtet Tempered Aciers traités Temprato
<b>HC45</b>	250 (200 - 350)	240 (140 - 300)	240 (130 - 280)			
<b>HC30</b>	160 (120 - 220)	200 (100 - 300)			60 (40 - 200)	
<b>HC35</b>	220 (200 - 350)	160 (100 - 300)			60 (40 - 200)	
<b>XC35</b>	120 (60 - 160)	100 (60 - 180)			80 (40 - 200)	
<b>HC20</b>			260 (180 - 350)			80 (40 - 120)
<b>K15M</b>				400 (300 - 600)		

### Ersatzteile Spare parts, Pièces de rechange, Parti di ricambio

	<b>SS 3,0-2</b> (M = 1,7-1,8 Nm)		<b>T 09</b>		<b>Fett</b> Grease, Graisse, Grasso
---	-------------------------------------	---	-------------	---	--

## B29 T-Nutenfräser *T-Slot milling cutters, Fraises à rainurer en T, Fresa per scanalature a "T"*

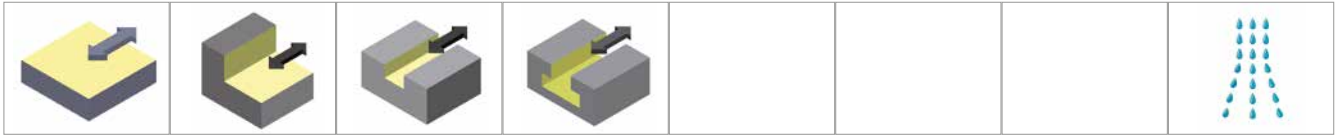



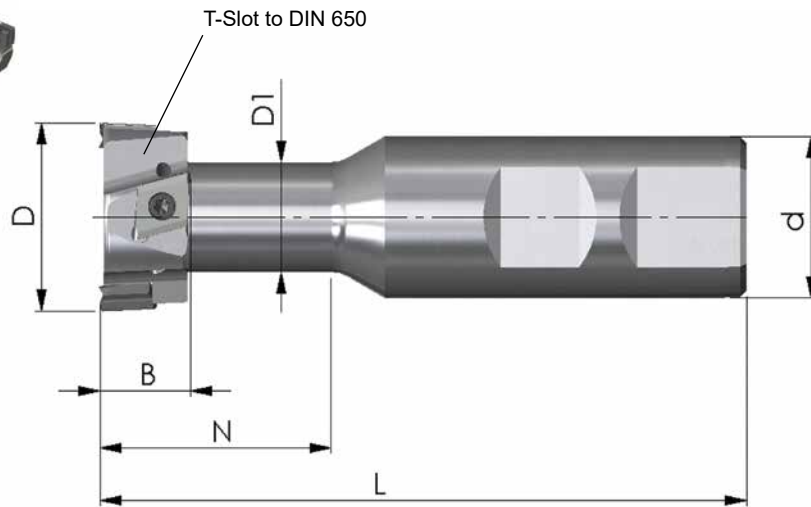



### Schafffräser DIN 1835-B *Shank type mills, Fraises à queue Weldon, Frese a gambo Weldon*

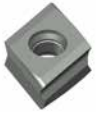

Bestell-Nr. <i>Order-No., Référence, Codice</i>	D	D1	B	L	N	d	Z	ZZ
90TN-32-14-B29-2	32	17	14,0	100	35	25	2	4

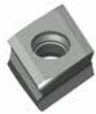

## B29 Fräswendepplatten und Schnittdaten

Milling inserts and parameters, Plaquettes de fraisage et paramètres, Inserti e parametri di taglio

			HC45 (code 41)	XC35 (code 46)	HC20 (code 53)				
	<b>JMB29-T08GRR06</b> IK 8,0x4,0 R0,6	Order- No.	B29B-SO41	B29B-XY46	B29B-TN53				
	 	f <sub>z</sub> [mm]	0,15 (0,05-0,25)	0,15 (0,05-0,25)	0,15 (0,05-0,25)				
	<b>JMB29-T08GR06</b> IK 8,0x4,0 R0,6	Order- No.	B29B-AX41	B29B-KZ46	B29B-YU53				
	 	f <sub>z</sub> [mm]	0,15 (0,05-0,25)	0,15 (0,05-0,25)	0,15 (0,05-0,25)				
			20	20	20				

V <sub>c</sub> [m/min]	Stahl Steel Acier Acciaio	Rostfrei Stainless Acier inoxydable Inossidabile	Guss Cast iron Fonte Ghisa	NE-Metalle Non-ferrous metals Non ferreux Metalli non ferrosi	Hochwarmfest Highly heat-resistant Superalliages Resistente al calore	Gehärtet Tempered Aciers traités Temprato
HC45	250 (200 - 350)	240 (140 - 300)	240 (130 - 280)			
XC35	120 (60 - 160)	100 (60 - 180)			80 (40 - 200)	
HC20			260 (180 - 350)			80 (40 - 120)

### Ersatzteile Spare parts, Pièces de rechange, Parti di ricambio

	<b>SS 3,0-2</b> (M = 1,7-1,8 Nm)		<b>T 09</b>		<b>Fett</b> Grease, Graisse, Grasso
---	-------------------------------------	---	-------------	---	--