

## B03 Eckfräser 90° *Step mills, Fraises à 90°, Frese per spallamenti retti*

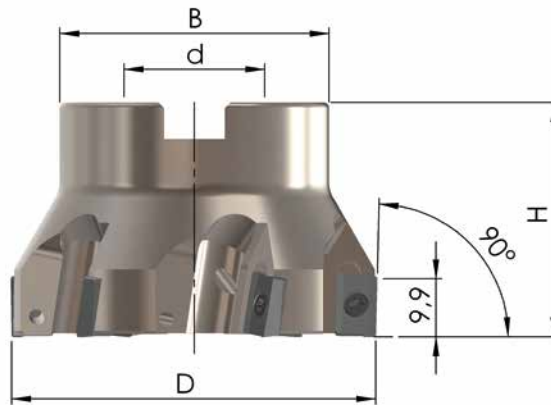

## Aufsteckfräser *Shell type mills, Fraises à alésage, Frese per attacco a manicotto*



Bestell-Nr. <i>Order-No., Référence, Codice</i>	D	H	d	B	Z	MS
90PP-040-10-16-5	40	40	16	38	5	MS-8x25-912
90PP-040-10-22-5	40	40	22	38	5	MS-10x25-912
90PP-050-10-5	50	40	22	46	5	MS-10x25-912
90PP-063-10-6	63	40	22	46	6	MS-10x25-912
90PP-080-10-7	80	50	27	58	7	MS-12x35-912

## Enge Teilung *close pitch, à pas réduit, a passo stretto:*

Bestell-Nr. <i>Order-No., Référence, Codice</i>	D	H	d	B	Z	MS
90PP-040-10-16-6	40	40	16	38	6	MS-8x25-912
90PP-040-10-22-6	40	40	22	38	6	MS-10x25-912
90PP-050-10-6	50	40	22	46	6	MS-10x25-912
90PP-063-10-7	63	40	22	46	7	MS-10x25-912
90PP-080-10-8	80	50	27	58	8	MS-12x35-912
90PP-100-10-9	100	50	32	78	9	MS-16x30-912

MS= Mittenschraube *Central screw, Vis centrale, Vite centrale di fissaggio*

## B03 Eckfräser 90° *Step mills, Fraises à 90°, Frese per spallamenti retti*

Schafffräser DIN 1835-B *Shank type mills, Fraises à queue Weldon, Frese a gambo Weldon*

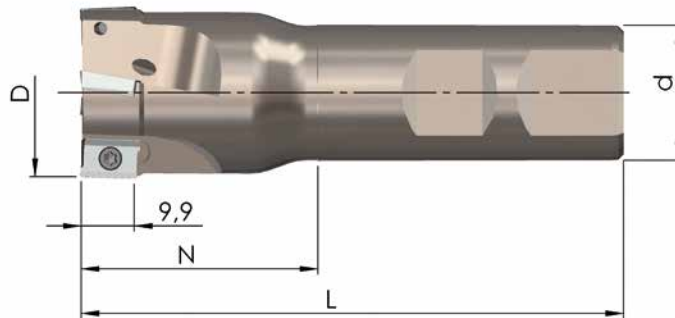

Bestell-Nr. <i>Order-No., Référence, Codice</i>	D	N	L	d	Z
90PP-12-10-1	12	27	100	25	1
90PP-14-10-1	14	27	100	25	1
90PP-16-10-1	16	30	100	25	1
90PP-20-10-2	20	30	100	25	2
90PP-25-10-3	25	37	100	25	3
90PP-32-10-4	32	43	100	25	4
90PP-40-10-5	40	43	100	25	5

Enge Teilung *close pitch, à pas réduit, a passo stretto:*

Bestell-Nr. <i>Order-No., Référence, Codice</i>	D	N	L	d	Z
90PP-16-10-2	16	27	100	25	2
90PP-18-10-2	18	27	100	25	2
90PP-20-10-3	20	26	100	25	3
90PP-22-10-3	22	26	100	25	3
90PP-25-10-4	25	41	100	25	4
90PP-28-10-4	28	41	100	25	4
90PP-30-10-4	30	41	100	25	4
90PP-32-10-5	32	41	100	25	5
90PP-36-10-5	36	41	100	25	5
90PP-40-10-6	40	41	100	25	6
90PP-22-10-3-L	22	41	115	25	3
90PP-28-10-4-L	28	60	118	25	4
90PP-32-10-5-L	32	60	120	25	5

## B03 Vielzahnfräser

Multi-Tooth milling cutters, Fraises multi-dents (hérisson),  
Frese a riccio



## Schafffräser DIN 1835-B Shank type mills, Fraises à queue Weldon, Frese a gambo Weldon

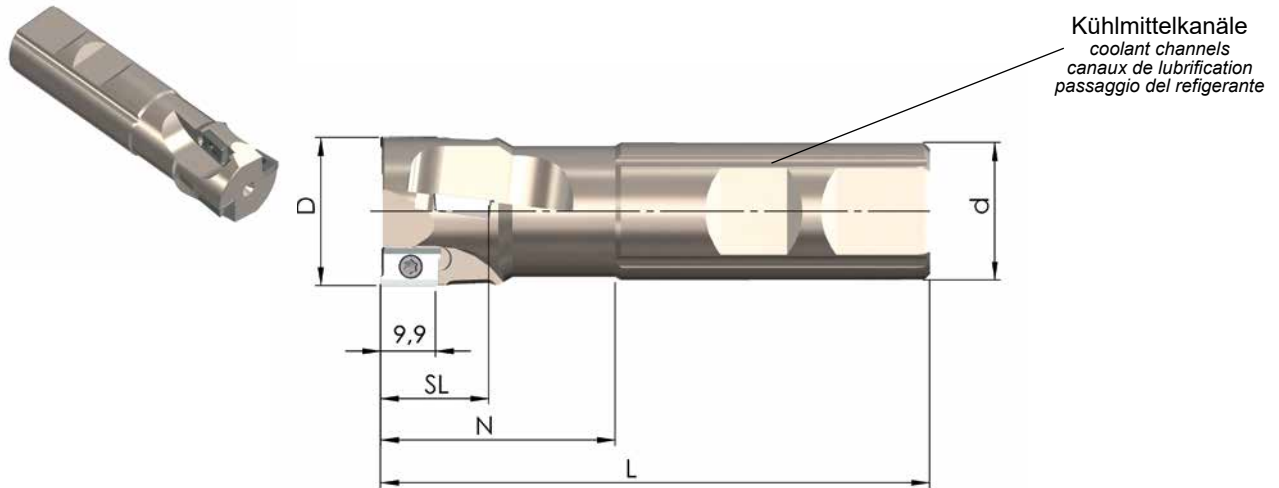

Bestell-Nr. <i>Order-No., Référence, Codice</i>	D	SL	N	L	d	Z <sub>eff.</sub>	ZZ
VZF 25-20-2	25	20	42	100	25	2	4
VZF 28-20-2	28	20	43	100	25	2	4
VZF 32-40-2	32	40	60	120	25	2	8

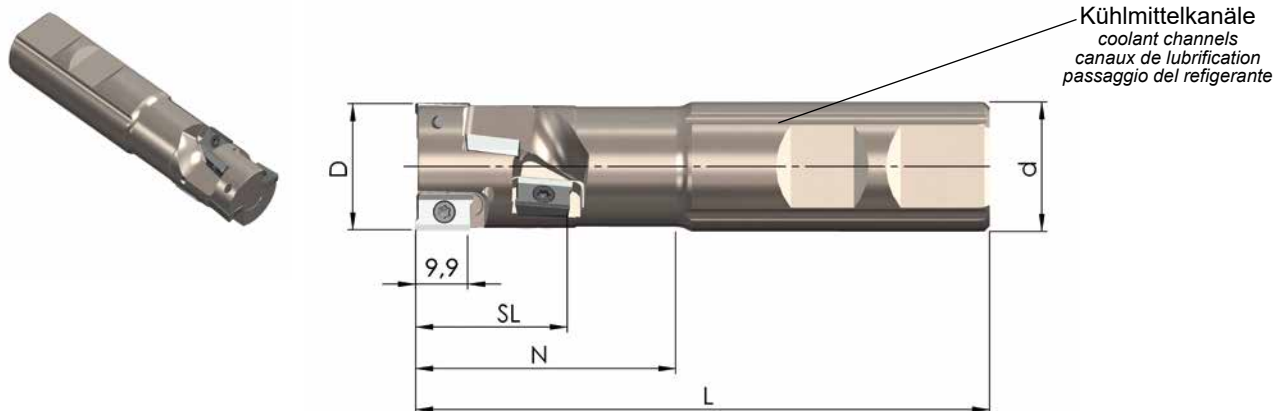

## Enge Teilung *close pitch, à pas réduit, a passo stretto:*

Bestell-Nr. <i>Order-No., Référence, Codice</i>	D	SL	N	L	d	Z <sub>eff.</sub>	ZZ
VZF 16-19-1	16	19	27	90	25	1	2
VZF 20-19-2	20	19	37	100	25	2	4
VZF 25-29-2	25	29	50	110	25	2	6
VZF 32-48-3	32	48	67	130	32	3	15

## B03 Vielzahnfräser

Multi-Tooth milling cutters, Fraises multi-dents (hérisson),  
Frese a riccio



Adapterversion Adapter version, Version adaptateur, Versione con giunto di prolungamento

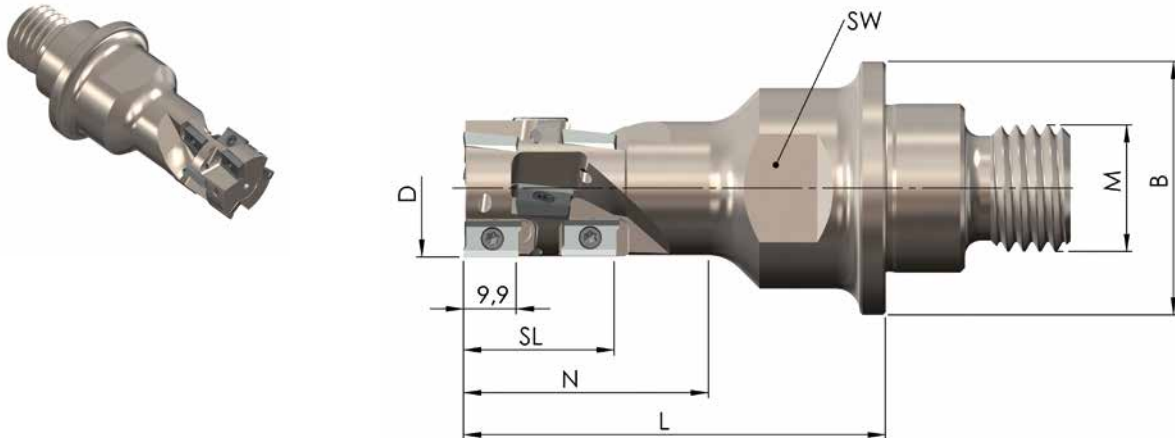

Bestell-Nr. <i>Order-No., Référence, Codice</i>	D	SL	N	L	B	M	SW	Z <sub>eff.</sub>	ZZ
<b>VZF 45-40-3 AD</b>	45	40	62	70	48	24	36	3	12
<b>Enge Teilung</b> <i>close pitch, à pas réduit, a passo stretto:</i>									
<b>VZF 28-29-3 AD</b>	28	29	46	80	48	24	32	3	9
<b>VZF 32-38-3 AD</b>	32	38	57	90	48	24	32	3	12
<b>VZF 40-48-4 AD</b>	40	48	80	90	48	24	32	4	20
<b>VZF 50-57-4 AD</b>	50	57	-	100	48	24	41	4	24

## B03 Fräswendeplatten und Schnittdaten

Milling inserts and parameters, Plaquettes de fraisage et paramètres, Inserti e parametri di taglio

			HT50 (code 22)	Ti20 (code 1)	HT35 (code 19)	KT28 (code 23)	HS20 (code 7)	KD16 (code 16)	
	<b>JMB03-71-</b> 10,0x7,0x3,18 <b>M S</b>	Order-No.	<b>B03A-EX22</b>	<b>B03A-FZ01</b>					
	<b>f<sub>z</sub></b> [mm]		0,10 (0,10-0,30)	0,10 (0,10-0,30)					
	<b>JMB03-71-</b> 10,0x7,0x3,18 <b>U</b>	Order-No.					<b>B03A-DZ07</b>		
	<b>f<sub>z</sub></b> [mm]						0,10 (0,10-0,30)		
	<b>JMB03-73-</b> 10,0x7,0x3,18 <b>M S</b>	Order-No.	<b>B03A-OD22</b>	<b>B03A-PE01</b>					
	<b>f<sub>z</sub></b> [mm]		0,10 (0,10-0,30)	0,10 (0,10-0,30)					
	<b>JMB03-72-</b> 10,7x7,0x3,97 <b>H M</b>	Order-No.	<b>B03A-JS22</b>	<b>B03A-LA01</b>		<b>B03A-KB23</b>			
	<b>f<sub>z</sub></b> [mm]		0,15 (0,10-0,30)	0,15 (0,10-0,30)		0,15 (0,10-0,30)			
	<b>JMB03-74-</b> 10,7x7,0x3,97 <b>H M</b>	Order-No.	<b>B03A-TH22</b>			<b>B03A-UK23</b>			
	<b>f<sub>z</sub></b> [mm]		0,15 (0,10-0,30)			0,15 (0,10-0,30)			
	<b>JMB03-71A-</b> 10,0x7,0x3,18 <b>S</b>	Order-No.		<b>B03A-HA01</b>					
	<b>f<sub>z</sub></b> [mm]			0,15 (0,10-0,30)					
	<b>JMB03-71A-</b> 10,0x7,0x3,18 <b>U</b>	Order-No.					<b>B03A-GR07</b>		
	<b>f<sub>z</sub></b> [mm]						0,10 (0,10-0,30)		
	<b>JMB03-72A-</b> 10,0x7,0x3,97 <b>S</b>	Order-No.	<b>B03A-MB22</b>					<b>B03A-NC16</b>	
	<b>f<sub>z</sub></b> [mm]		0,15 (0,10-0,30)					0,15 (0,10-0,30)	
	<b>JMB03-73A-</b> 10,0x7,0x3,18 <b>S</b>	Order-No.			<b>B03A-RF19</b>				
	<b>f<sub>z</sub></b> [mm]				0,10 (0,10-0,30)				
	<b>JMB03-73A-</b> 10,0x7,0x3,18 <b>U</b>	Order-No.					<b>B03A-SK07</b>		
	<b>f<sub>z</sub></b> [mm]						0,10 (0,10-0,30)		
			20	20	20	20	20	10	

## B03 Fräswendepplatten und Schnittdaten

Milling inserts and parameters, Plaquettes de fraisage et paramètres, Inserti e parametri di taglio

V <sub>c</sub> [m/min]	Stahl Steel Acier Acciaio	Rostfrei Stainless Acier inoxydable Inossidabile	Guss Cast iron Fonte Ghisa	NE-Metalle Non-ferrous metals Non ferreux Metalli non ferrosi	Hochwarmfest Highly heat-resistant Superalliages Resistente al calore	Gehärtet Tempered Aciers traités Temprato
<b>HT50</b>	220 (160 - 300)	200 (100 - 300)	240 (200 - 300)			
<b>Ti20</b>	250 (220 - 280)	220 (180 - 300)	260 (180 - 350)			
<b>HT35</b>	160 (120 - 220)	200 (100 - 300)			60 (40 - 200)	
<b>KT28</b>			260 (180 - 350)			80 (40 - 120)
<b>HS20</b>				400 (300 - 600)		
<b>KD16</b>				600 (500 - 1000)		

### Ersatzteile Spare parts, Pièces de rechange, Parti di ricambio

	<b>SS 3,0-1</b> (M = 1,7-1,8 Nm)		<b>T 09</b>		<b>Fett</b> Grease, Graisse, Grasso
---	-------------------------------------	---	-------------	---	--